

30%

Take advantage **NOW** of the **30% TAX DEDUCTION** on all machine purchases

F3000S MATERIAL POSITIONER

Positioning, Accuracy, Productivity Solutions

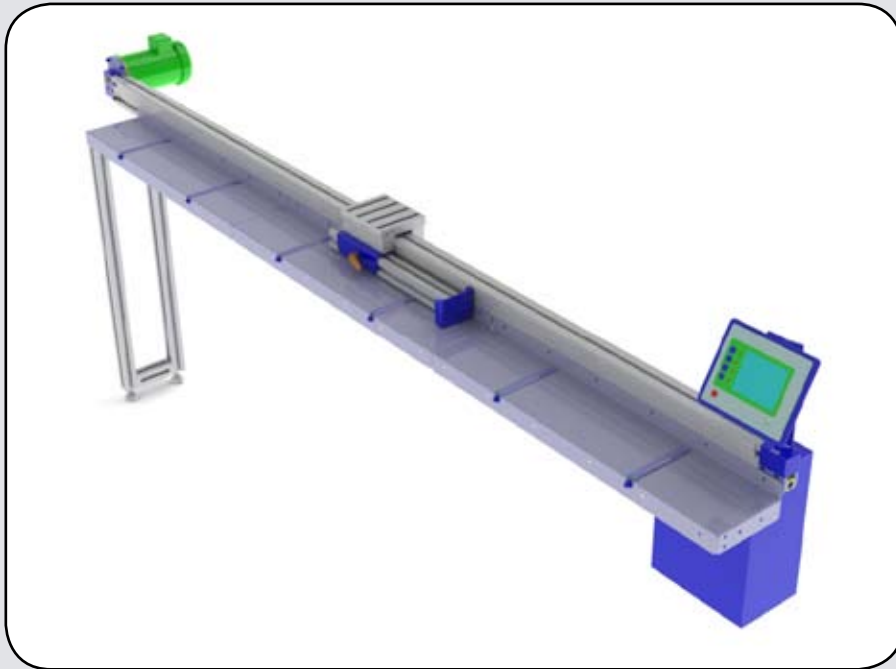

F3000S – Flexible design and application material feeder suitable for positioning applications.

Simple integration with modular automation units in machining applications. Retrofit installation onto your existing machinery for complete production solutions. Combining with automatic loaders for continuous operation, completely unsupervised, production systems.

Ball-screw actuated or belt drive designs with fast positioning and ± 0.1 mm repeatable accuracy. Heavy and light-duty designs from structural steel applications to small profile feeding.

Multiple head attachment options with pneumatic clamp (bundle feeding), magnetic clamping or a simple push feeder. Integrated length stop function with pneumatic or magnetic brake for sturdy stop.



Features

- Suitable for construction of complete multi-operation production systems
- Complete applications - made from scratch or retrofit installation to your existing machines
- Automatic length-stop or bar feed modes
- Up to 6000 mm travel with feed speeds up to 700 mm/s
- Accurate positioning with lock-in stop
- Electronic zero-point calibration with close cut capability

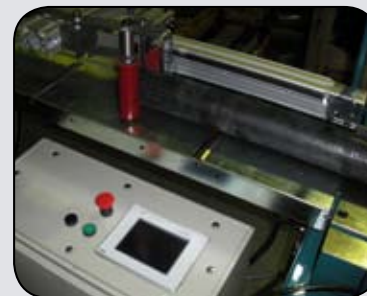

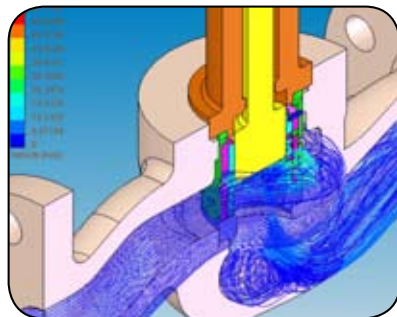
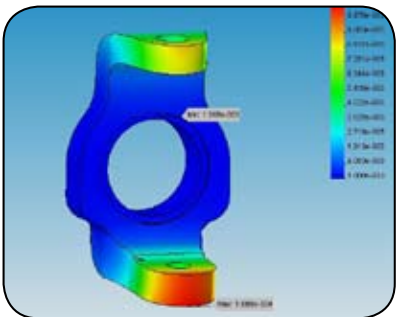
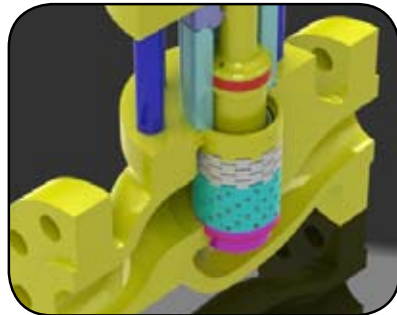
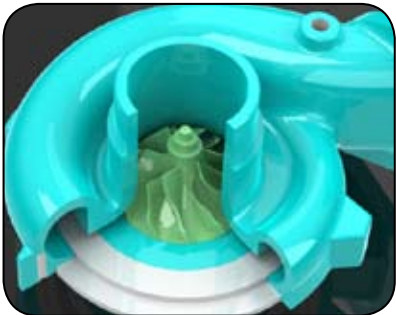
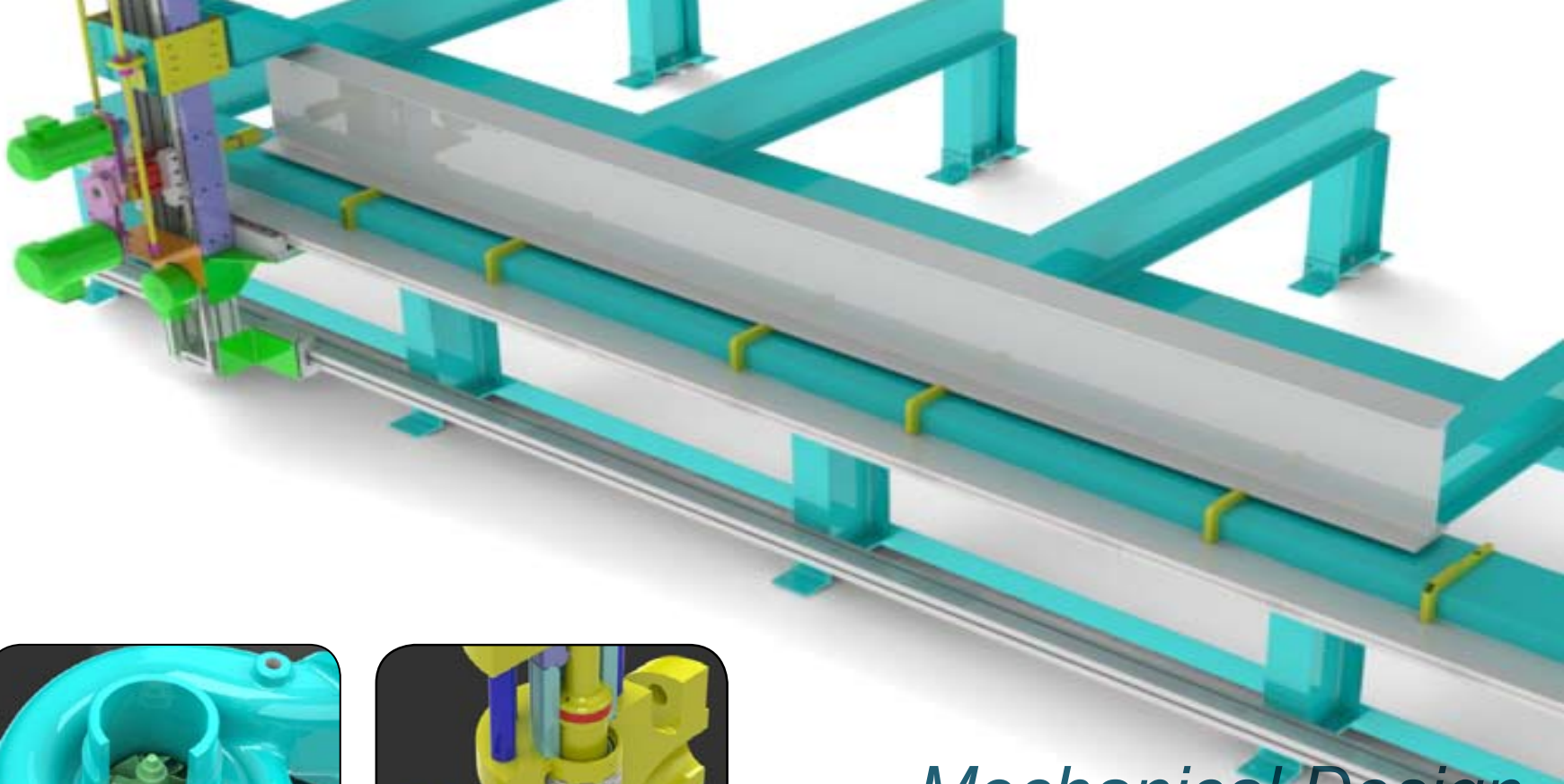
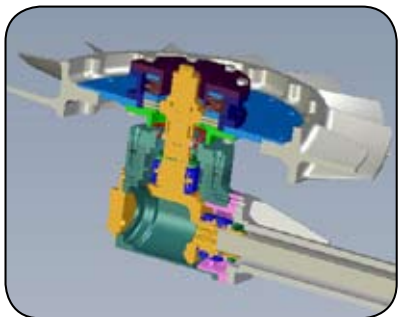
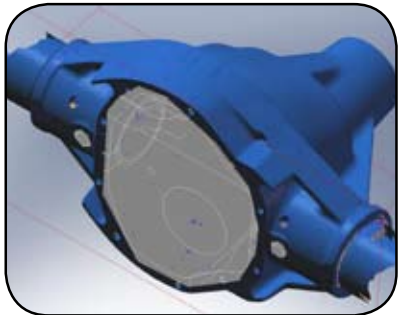

*Mechanical Design
Development
Implementation
Innovation*



18 Jeffrey Street Dandenong VIC 3175 AUSTRALIA

T +61 3 9793 9358 F +61 3 9793 9308

reconeng@reconeng.com.au

www.reconeng.com.au